

RAINPROOF DYNAMO LED FLASHLIGHT

SB-6027/Eco-friendly dynamo LED Flashlight

www.SORBO.cn

This product adopts the principle of cranking for power generation. Cranking the handle to drive the generator to generate alternating current by professional designed driving gear. Then changing the alternating current into DC after commutating and voltage stabilizing which to charge its built in 80mAh, 3.6V battery.

Switch models: Low level lighting→ high level lighting→flashing→ off.

Functions:

- ▶ Cranking for power generation
- ▶ Switch models: Low level lighting→high level lighting→flashing→off
- ▶ Rainproof: IP44
- ▶ Long distance lighting and close-range lighting

Features:

- ▶ Cranking for power, low noise but high efficiency.
- ▶ Rainproof function
- ▶ No batteries are needed
- ▶ Long life-span
- ▶ Fashion design

1)Lighting:

High level lighting time after 1 minute cranking	≥12 min
Low level lighting time after 1 minute cranking	≥29 min
Close-range lighting time after 1 minute cranking	≥25 min
Flashing time after 1 minute cranking	≥45 min
The Max. Luminous Flux of high level lighting	≥10Lm
The Max. Luminous Flux of low level lighting	≥4.5Lm
The Max. Luminous Flux of close-range lighting	≥2.5Lm
High level lighting time after being charged fully	≥50 min
Low level lighting time after being charged fully	≥2.5hr
Close-range lighting time after being charged fully	≥2 hr
Flashing time after being charged fully	≥3 hr

2)Main parts life-span:

Switch	≥10000 Times
The whole unit	≥5 Years
The plastic part	≥5 Years

3) Size and Weight:

Product size	131*53*31mm
Product weight	120 g

4) Others:

Specification of built-in battery	NI-MH, 80mAh, 3.6 V
Motor	2.5W Brushless

- 1.Lighting Switch
- 2.Close-range Lighting Switch
- 3.Head of handle
- 4.Drainhole
- 5.Cranking Handle
- 6.Close-range Lighting Cover

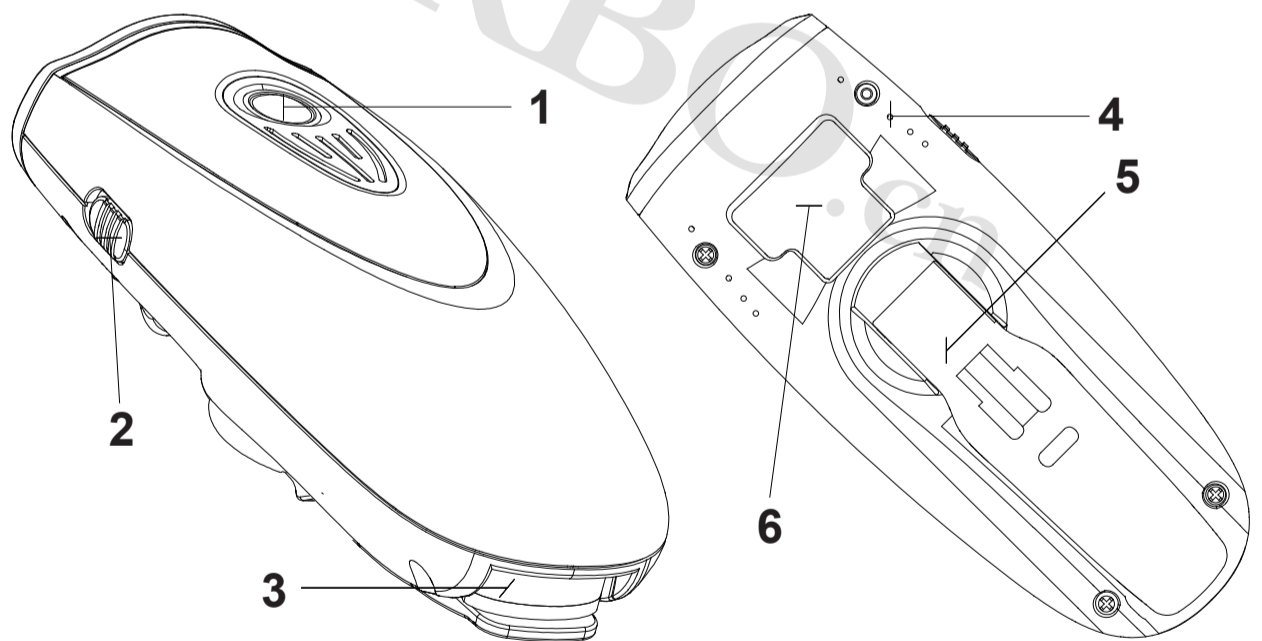

MADE IN CHINA